

GRTH

Präzisionstechnik

+ Abplanalp TOOLS



CNC-Präzisionsbohrfutter

CNC-Drill chucks
Mandrins de perçage



Sonderaktion - Special offer - Offre spéciale

CNC-Bohrfutter für Rechts- und Linkslauf

DIN 69871 AD

CNC-Drill chucks for clockwise and counter clockwise rotation

Mandrins de perçage CNC pour rotation gauche-droite



Verwendung:

Zur Aufnahme von Werkzeugen mit Zylinderschaft.

Application:

For mounting tools with straight shanks.

Application:

Pour le serrage d'outils avec queue cylindrique.

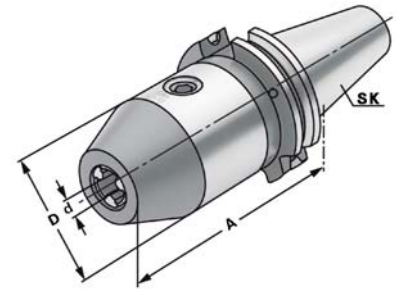

G 6,3 12.000 min⁻¹



≤ 0,03

Lieferung inkl. Spanschlüssel Delivery incl. wrench Clé de serrage inclus

Bestell-Nr. Order no. Référence	SK	d	Spannbereich Capacity Capacité	A	D	Euro
302.9908	SK 30	0 – 8		70	36	225,00
302.9913	SK 30	1,0 – 13		111	50	187,00
302.9916	SK 30	2,5 – 16		116	50	201,00
402.9908	SK 40	0 – 8		70	36	169,00
402.9913	SK 40	1,0 – 13		90	50	120,00
402.9916	SK 40	2,5 – 16		95	50	130,00
502.9913	SK 50	1,0 – 13		90	50	169,00
502.9916	SK 50	2,5 – 16		95	50	172,00

CNC-Bohrfutter für Rechts- und Linkslauf

DIN 2080

CNC-Drill chucks for clockwise and counter clockwise rotation

Mandrins de perçage CNC pour rotation gauche-droite



Verwendung:

Zur Aufnahme von Werkzeugen mit Zylinderschaft.

Application:

For mounting tools with straight shanks.

Application:

Pour le serrage d'outils avec queue cylindrique.

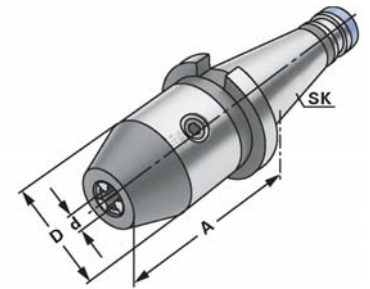

G 6,3 12.000 min⁻¹



≤ 0,03

Lieferung inkl. Spanschlüssel Delivery incl. wrench Clé de serrage inclus

Bestell-Nr. Order no. Référence	SK	d	Spannbereich Capacity Capacité	A	D	Euro
301.9908	SK 30	0 – 8		60	36	225,00
301.9913	SK 30	1,0 – 13		90	50	187,00
301.9916	SK 30	2,5 – 16		95	50	199,00
401.9908	SK 40	0 – 8		63	36	169,00
401.9913	SK 40	1,0 – 13		83	50	125,00
401.9916	SK 40	2,5 – 16		88	50	135,00
501.9913	SK 50	1,0 – 13		85	50	176,00
501.9916	SK 50	2,5 – 16		90	50	187,00

CNC-Bohrfutter für Rechts- und Linkslauf

JIS B 6339 AD

CNC-Drill chucks for clockwise and counter clockwise rotation

Mandrins de perçage CNC pour rotation gauche-droite



Verwendung:

Zur Aufnahme von Werkzeugen mit Zylinderschaft.

Application:

For mounting tools with straight shanks.

Application:

Pour le serrage d'outils avec queue cylindrique.

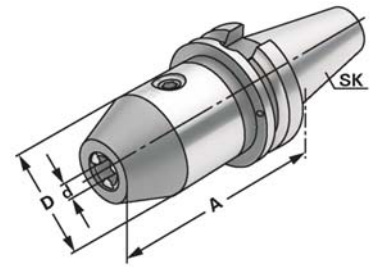

G 6,3 12.000 min⁻¹



≤ 0,03

Lieferung inkl. Spannschlüssel Delivery incl. wrench Clé de serrage inclus

Bestell-Nr. Order no. Référence	SK	d	Spannbereich Capacity Capacité	A	D	Euro
305.9908	BT 30	0 – 8		73	36	225,00
305.9913	BT 30	1,0 – 13		93	50	187,00
305.9916	BT 30	2,5 – 16		98	50	201,00
405.9908	BT 40	0 – 8		78	36	169,00
405.9913	BT 40	1,0 – 13		98	50	120,00
405.9916	BT 40	2,5 – 16		103	50	130,00
505.9913	BT 50	1,0 – 13		111	50	169,00
505.9916	BT 50	2,5 – 16		113	50	172,00

CNC-Bohrfutter für Rechts- und Linkslauf

DIN 69893-1 HSK A

CNC-Drill chucks for clockwise and counter clockwise rotation

Mandrins de perçage CNC pour rotation gauche-droite



Verwendung:

Zur Aufnahme von Werkzeugen mit Zylinderschaft.

Application:

For mounting tools with straight shanks.

Application:

Pour le serrage d'outils avec queue cylindrique.

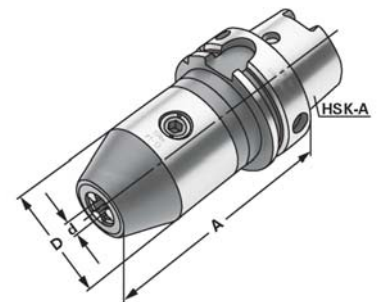

G 6,3 15.000 min⁻¹



≤ 0,03

Lieferung inkl. Spannschlüssel Delivery incl. wrench Clé de serrage inclus

Bestell-Nr. Order no. Référence	HSK	d	Spannbereich Capacity Capacité	A	D	Euro
A63.9913	HSK-A 63	1,0 – 13		104	50	199,00
A63.9916	HSK-A 63	2,5 – 16		109	50	209,00
A100.9913	HSK-A 100	1,0 – 13		107	50	253,00
A100.9916	HSK-A 100	2,5 – 16		112	50	269,00

„Präzision für höchste Ansprüche“
„Precision for highest requirements“

CNC-Bohrfutter mit zentraler Kühlmittelzufuhr

DIN 69880

CNC-Drill chucks with central coolant

Mandrins de perçage CNC avec arrosage centrale



Verwendung:

Zur Aufnahme von Werkzeugen mit Zylinderschaft.

Application:

For mounting tools with straight shank.

Application:

Pour le serrage d'outils avec queue cylindrique.

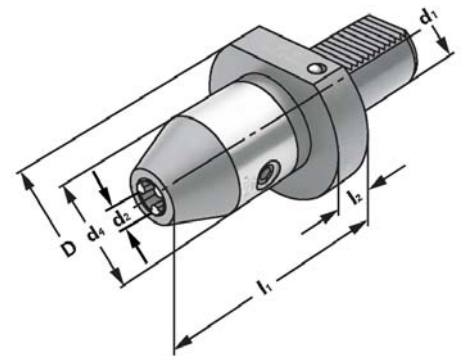

↗ ≤ 0,03

Lieferung inkl. Spannschlüssel Delivery incl. wrench Clé de serrage inclus

Bestell-Nr. Order no. Référence	d ₁	d ₂	Spannbereich Capacity Capacité	d ₄	D	l ₁	l ₂	Euro
209.9913	20	1,0 – 13		50	50	88	18	183,00
309.9913	30	1,0 – 13		50	68	93	22	183,00
309.9916	30	2,5 – 16		50	68	98	22	190,00
409.9913	40	1,0 – 13		50	83	93	22	183,00
409.9916	40	2,5 – 16		50	83	98	22	190,00
509.9913	50	1,0 – 13		50	98	101	30	207,00
509.9916	50	2,5 – 16		50	98	106	30	217,00

CNC-Bohrfutter für Rechts- und Linkslauf

ISO 26623 C6

CNC-Drill chucks for clockwise and counter clockwise rotation

Mandrins de perçage CNC pour rotation gauche-droite



Verwendung:

Zur Aufnahme von Werkzeugen mit Zylinderschaft.

Application:

For mounting tools with straight shank.

Application:

Pour le serrage d'outils avec queue cylindrique.

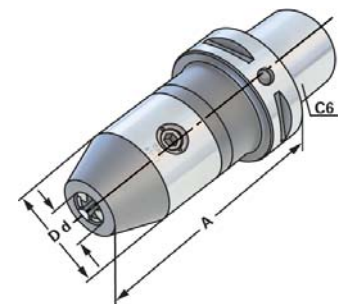

↗ ≤ 0,03

G 6,3 15.000 min⁻¹

Bestell-Nr. Order no. Référence	PSK	d	Spannbereich Capacity Capacité	A	D	Euro
C6.15.13	C6	1 – 13		100	50	390,00
C6.15.16	C6	2,5 – 16		100	50	400,00

Mehr Produkte und Informationen finden Sie in unserem Hauptkatalog.

Please check our catalogue for more products and detailed informations.

Vous trouvez plus de produits et d'informations dans notre catalogue général.

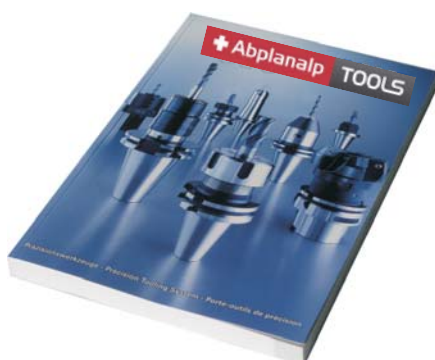

ABPLANALP CONSULTING Sp. z o.o.
Dział Narzędzi Skrawających
 ul. Kostrzyńska 36
 02-979 Warszawa
 tel.: 022 379 44 00
 fax.: 022 379 44 90
 e-mail: narzedzia@abplanalp.pl